

2021

## Système Anti-Chavirage ACS

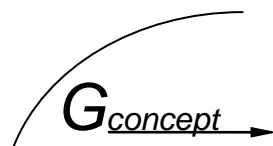

WINNER ALL MULTIHULLS CLASS  
ROUTE DU RHUM 2018

*Research and development*  
*Roger Ganovelli :*  
*+33 6 99 19 41 06*  
*ganovelli.concept@gmail.com*

# PALMARES - ACS Ganovelli Concept

« 15 years of performance »

2018	<p>ROUTE DU RHUM :(GClass)</p> <ul style="list-style-type: none"> <li>• 1ere IDEC Francis JOYON</li> <li>• 4eme REMADE Romain PILLARD</li> </ul> <p>ROUTE DU RHUM :(Multi50)</p> <ul style="list-style-type: none"> <li>• 1ere Réauté chocolat Armel TRIPON</li> <li>• 3eme Solidaire Thibaut VAUCHEL CAMUS</li> <li>• Arkema Lalou ROUCAYROL</li> </ul> <p>ROUTE DU RHUM :(Class Rhum)</p> <ul style="list-style-type: none"> <li>• TS52 Gerald BIBOT</li> <li>• Outremer 5X Yann MARILLEY</li> <li>• A capella Charlie CAPELLE</li> <li>• ORMA 40 Gilles BUCKENHOUT</li> </ul>
2014	<p>ROUTE DU RHUM :(GClass)</p> <ul style="list-style-type: none"> <li>• MOD 70 /PAPREC Yann Elies</li> <li>• IDEC Francis JOYON</li> </ul> <p>ROUTE DU RHUM :(Multi50)</p> <ul style="list-style-type: none"> <li>• 2eme Lalou Roucayrol</li> <li>• 4eme Yves le Blevec</li> </ul> <p>ROUTE DU RHUM :(Class Rhum)</p> <ul style="list-style-type: none"> <li>• 1ere ANEO Anne Cazeneneuve</li> <li>• 7eme Acapella Charlie Capelle</li> </ul>
2013	<p>IDEC (GClass) Francis JOYON Record de la traversée de l'Atlantique nord en solitaire.</p>
2010	<p>ROUTE DU RHUM :(GClass)</p> <ul style="list-style-type: none"> <li>• 1<sup>ème</sup> GROUPAMA 3 Franck CAMMAS</li> <li>• 2<sup>ème</sup> IDEC Francis JOYON</li> </ul> <p>ROUTE DU RHUM :(Multi 50)</p> <ul style="list-style-type: none"> <li>• 2<sup>ème</sup> REGION AQUITAINE Lalou ROUCAYROL</li> <li>• 7<sup>ème</sup> NAVIGUEZ ANNE CAZENEUVE Anne CAZENEUVE</li> <li>• 9<sup>ème</sup> NOOKTA Gilles BUEKENHOUT</li> </ul> <p>ROUTE DU RHUM :(Class RHUM)</p> <ul style="list-style-type: none"> <li>• 4<sup>ème</sup> ACAPELLA Charlie CAPELLE</li> </ul> <p>VENDEE / SAINT PETERSBOURG (Multi 50)</p> <ul style="list-style-type: none"> <li>• 1<sup>ème</sup> ACTUAL Yves LE BLEVEC</li> <li>• 4<sup>ème</sup> REGION AQUITAINE Lalou ROUCAYROL</li> </ul>
2009	<p>IDEC (GClass) Francis JOYON Record FRANCE/ILE MAURICE</p> <p>TRANSAT EN DOUBLE JACQUE VABRE :(Classe 50 pieds)</p> <ul style="list-style-type: none"> <li>• 3<sup>ème</sup> REGION AQUITAINE Lalou ROUCAYROL</li> </ul>
2008	<p>IDEC (GClass) Francis JOYON Record de la ROUTE DE LA DECOUVERTE</p> <p>IDEC (GClass) Francis JOYON Record du TOUR DU MONDE EN SOLITAIRE</p>
2007	<p>TRANSAT EN DOUBLE JACQUE VABRE :(Classe ORMA)</p> <ul style="list-style-type: none"> <li>• 1<sup>er</sup> GROUPAMA 2 Franck CAMMAS</li> <li>• 3<sup>ème</sup> BANQUE POPULAIRE Pascal BIDEGORRY</li> <li>• 4<sup>ème</sup> BROSSARD Yvan BOURGNON</li> <li>• 5<sup>ème</sup> SOPRA GROUP Antoine KOCH</li> </ul> <p>TRANSAT EN DOUBLE JACQUE VABRE :(Classe 50 pieds)</p> <ul style="list-style-type: none"> <li>• 3<sup>ème</sup> REGION AQUITAINE Lalou ROUCAYROL</li> </ul> <p>IDEC (GClass) Francis JOYON Record de traversée de la Manche</p>
2006	<p>ROUTE DU RHUM :(Classe ORMA)</p> <ul style="list-style-type: none"> <li>• 2<sup>ème</sup> BANQUE POPULAIRE Pascal BIDEGORRY</li> <li>• 5<sup>ème</sup> GROUPAMA 2 Franck CAMMAS</li> <li>• 6<sup>ème</sup> BROSSARD Yvan BOURGNON</li> <li>• 8<sup>ème</sup> REGION GUADELOUPE</li> <li>• 9<sup>ème</sup> SOPRA GROUP Antoine KOCH</li> </ul> <p>HYDRAPLANEUR Yves PARIER</p> <ul style="list-style-type: none"> <li>• Record distance parcourue /24h(60pieds/equip.)</li> <li>• Record tour de Gran Canaria</li> </ul>
2005	<p>IDEC (GClass) Francis JOYON Record de traversée de l'Atlantique en solitaire</p>
2004	<p>GROUPAMA 2 (ORMA) Franck CAMMAS Champion ORMA</p>



## ANTI-CAPSIZE SYSTEM

The ACS (Anti-Capsize System) is an innovative automatic and autonomous safety system designed to overcome the problem of multihull capsizes.

**Automatic** : when a critical angle of heeling or pitch poling is exceeded, the ACS acts directly by progressively releasing the sails.

**Autonomous** :

- The ACS depends on no external equipment or instrumentation (electronic or computerised) thus ensuring a high level of stability and reliability.
- Negligible consumption on standby (0.010A) allowing the system to remain switched on without risk of electrical overconsumption.

The result of two years of development and trials, the *Anti-Capsize System* was patented in 2003 by Marc and Roger Ganovelli.

On the market since 2005, the system has satisfied all available tests for racing multihulls.

Custom-fitted aboard each vessel, the ACS offers indispensable automated safety in the search for extreme performance on multihulls: automatic release of the sails when pre-set angles (configured to measure) of heeling and pitch poling are exceeded.

To date, ACS has been installed and tested on several of the 60-foot trimarans participating in the Route du Rhum 2006/2010/2014/2018 and in other ocean races :

GROUPAMA 2  
BANQUE POPULAIRE  
BROSSARD  
SOPRA GROUP  
REGION GUADELOUPE  
MEDIATIS REGION AQUITAINE  
PORT MEDOC-Aquitaine  
TS 50  
A Capella  
ACTUAL  
GROUPAMA 3  
IDEC

Franck CAMMAS  
Pascal BIDEGORRY  
Yvan BOURGNON  
Antoine KOCH  
Claude THELIER  
Yves PARLIER  
Lalou ROUCAYROL  
Dominique MARSAUDON  
Charlie CAPELLE  
Yves LE BLEVEC  
Franck CAMMAS  
Francis JOYON

Other installations are currently in progress.

All in all nearly 70 ACS are currently sailing over the world.

This is an indispensable safety system whether for solitary or team races. Minimal in size, the ACS is suitable for all types of configuration (hydraulic or electrical).



**OPERATING PRINCIPLE of the ACS :**

**Mécanismes de détection : partie commande**



**3**

**PANIC BUTTON**  
Ordre manuel d'urgence de choquer les voiles



**1**

**BOITIER de DETECTION**  
Des angles de gîte et d'enfournement



**2**

**MODULE TELECOMMANDE**  
Commande à distance

**ALIMENTATION à BORD :**



12V/cc, 0,010A en veille  
(2A en phase largage)

**Mécanismes de largage : partie opérative**

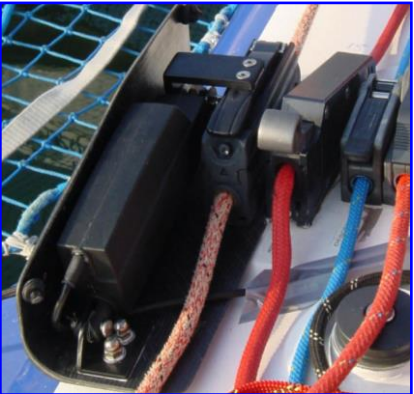

**4**

**VERIN DE LARGAGE AUTOMATIQUE SUR BLOQUEUR TYPE XX**  
Montage sur mesure s'adaptant aux bloqueurs présents sur le pont



**5**

**VERIN DE LARGAGE POUR CAM-CLEAT OFFSHORE type Harken**



**6**

**ELECTROVANNE de vérin hydraulique**

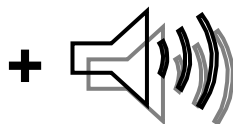

## Detection

### 1. Detection box:

An electronic unit that controls the boat's trim. Permanently installed in the cabin, it monitors the heeling and pitch poling of the vessel. When the pre-set angles are exceeded (or the panic button is activated) the detection box activates the mechanical units which release the sheets. It can be configured to measure.



### 2. Panic button :

Manual release of the sheets is possible by means of emergency cutout bracelets (panic button). This manual emergency override can be installed near the helm, at the foot of the mast, or wherever, depending on the needs of the skipper.



### 3. Remote control - distance release:

Allows the automatic distance release of the sheets.  
(Waterproof and Shockproof remote control)





## Release

### 4. Automated clutch:

Permits progressive release of the sheets: the clutch releases only what is needed in order to regain the usual trim.



Use of an industrial product ensures reliability when the sheets are blocked.

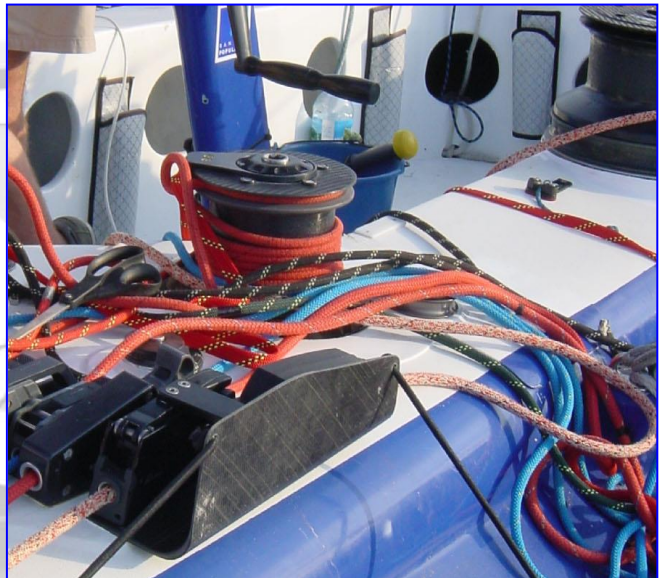
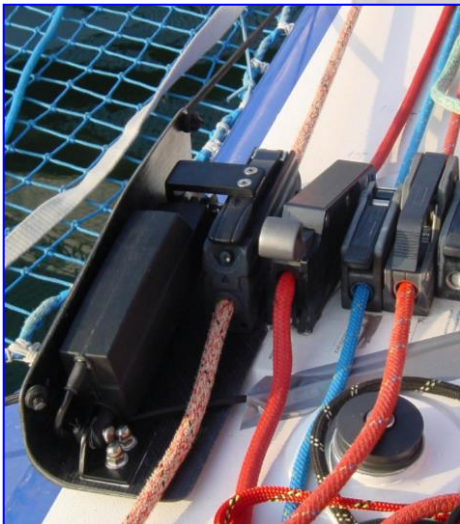

5. Automated « Offshore Cam-matic® Cleat »:

Permits automatic or distance release of the sheet as well as normal use of the cleat.



Use of a Harken™ product assures reliability when the sheets are blocked.

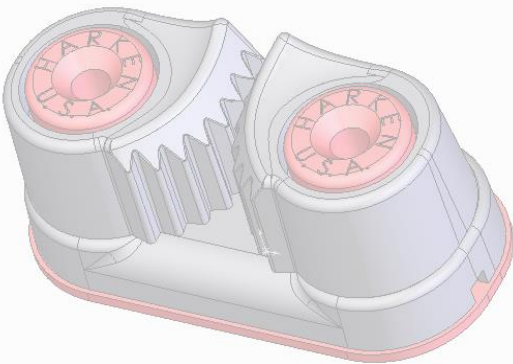
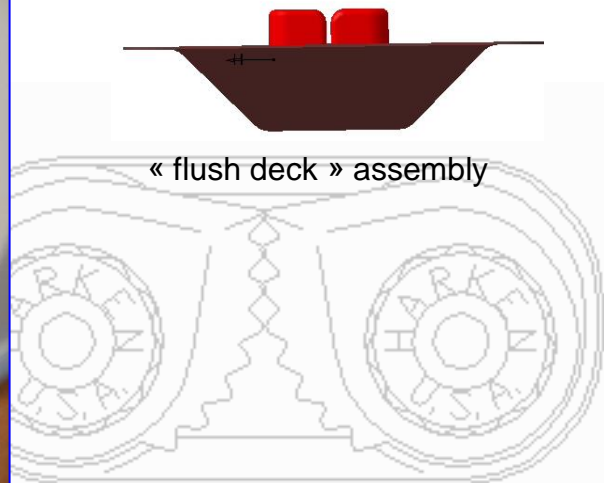

6. Solenoid valve for hydraulic cylinder:

Valve electronically directed by the ACS, which controls the movement of the hydraulic cylinder (generally used for the mainsail) or of the captive reel winch.





## Technical specifications

- ❖ Command boxes: (detection box + junction box)

*weight 400g*

Consumption on standby 10mA

Consumption at moment of release until 8A (depending on the type and number of release units)

Functions:

- ✓ regulation of release (sensitivity): 6 positions
- ✓ 11 pre-set angles of heeling:
  - « 4; 7; 10; 13; 16; 19; 22; 25; 30; 35; 40; OFF » degrees (margin of error  $\pm 2^\circ$ )
- ✓ 11 pre-set angles of pitch poling:
  - « 2; 4; 6; 8; 10; 12; 14; 16; 18; 20; 25; OFF » degrees (margin of error  $\pm 2^\circ$ )
- ✓ up to 4 panic buttons:
  - « 1 on the command box; 3 others to be installed where needed »
- ✓ 2 switches for setting the release unit:
  - « automated Spinlock™ Clutch XX® and/or automated Offshore Cam-Matic® Cleat (Harken™) and/or hydraulic solenoid valve »
- ✓ 1 switch (3 positions) enabling use of « manual », « automatic » and « OFF » modes
- ✓ 1 release alarm incorporated in the junction box (external release alarm optional)

- ❖ Release devices:

- deck clutch (Spinlock™ Clutch XX®) controlled by linear actuators:

consumption 2A on activation, 1A after (polarised connection)

*weight 800g*

- Offshore Cam-Matic® Cleat (Harken™) controlled by linear actuators:

consumption 2A on activation, 0.5A after (polarised connection)

*weight 500g*

- hydraulic solenoid valve closed on standby: consumption 2A on activation, 0.7A after (polarised connection); earthed in order to avoid corrosion of the

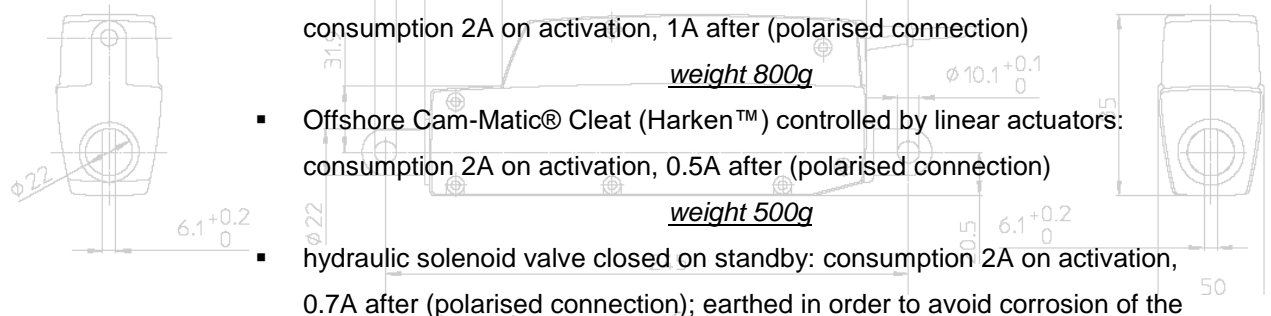

magnetic core

*weight 300g*

- ❖ Various:

- ✓ Copper and silvery tinned wiring
- ✓ fuse 10A ( $\varnothing 6 \times 32$ )
- ✓ plastic fire-resistant boxes (ABS and PVC)
- ✓ high-resistance external elements (waterproof linear actuators/servos IP68 equipped with extra fairing; metal components in stainless steel 316L and treated aluminium 5086)

